

S-44 RPT

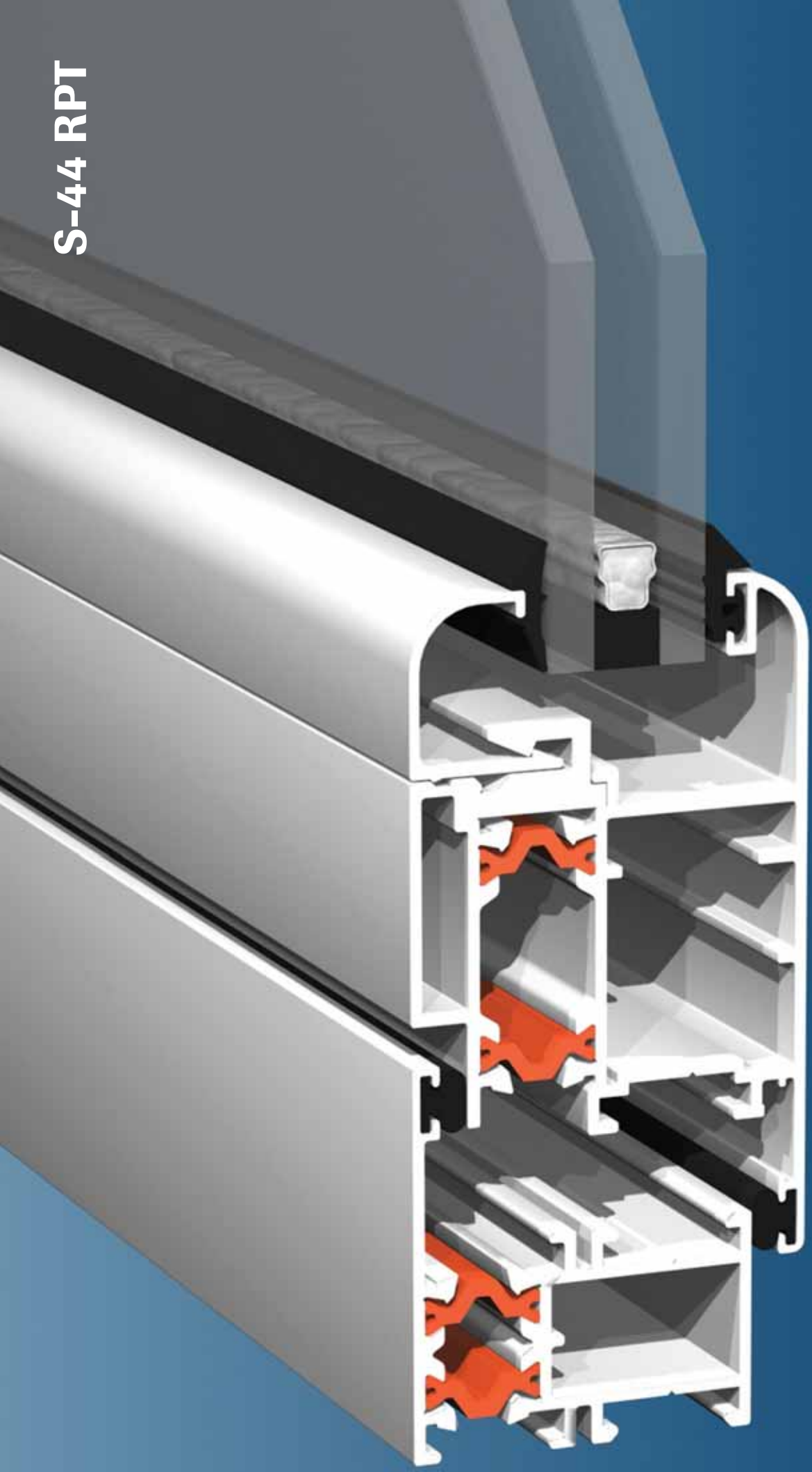



SUPERBA 44 RPT

Ventana de abatir / proyección / puerta
con doble vidrio (termopanel)

Superba 44 RPT

Ventana de abatir / proyección / puerta

Perfiles

Escala 1:1

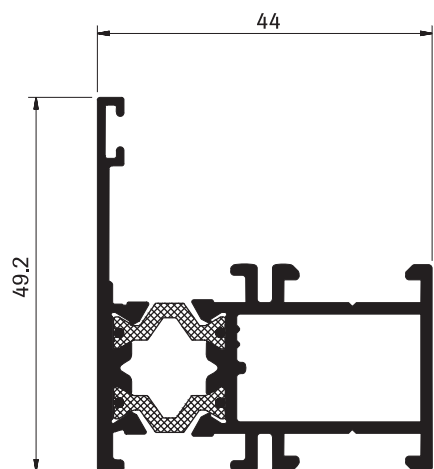

4481
MARCO
Peso: 0.919 kg/M
Espesor: 1.5 mm

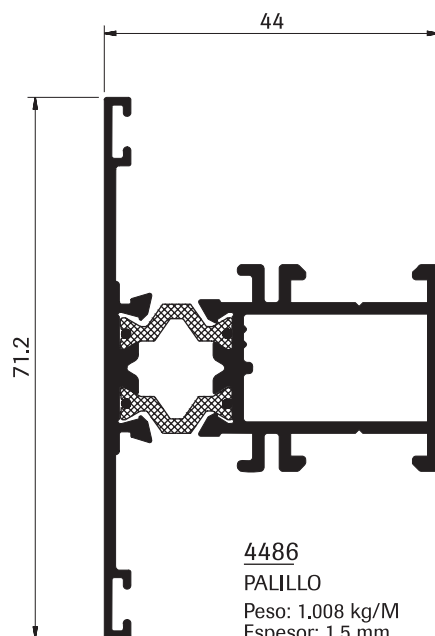

4486
PALILLO
Peso: 1.008 kg/M
Espesor: 1.5 mm

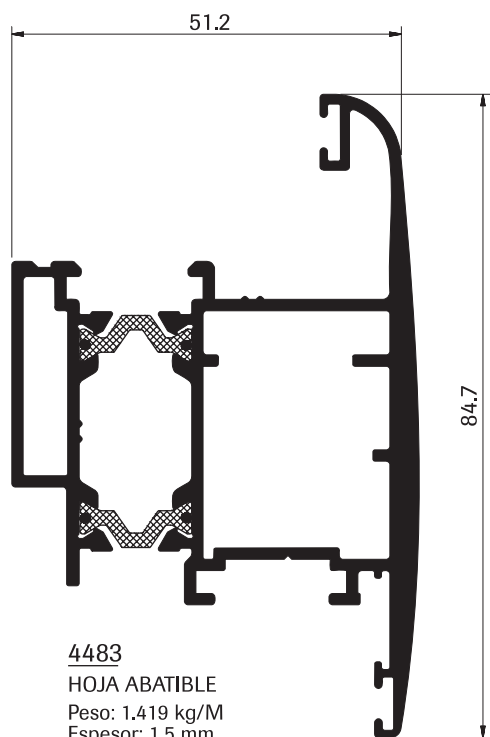

4483
HOJA ABATIBLE
Peso: 1.419 kg/M
Espesor: 1.5 mm

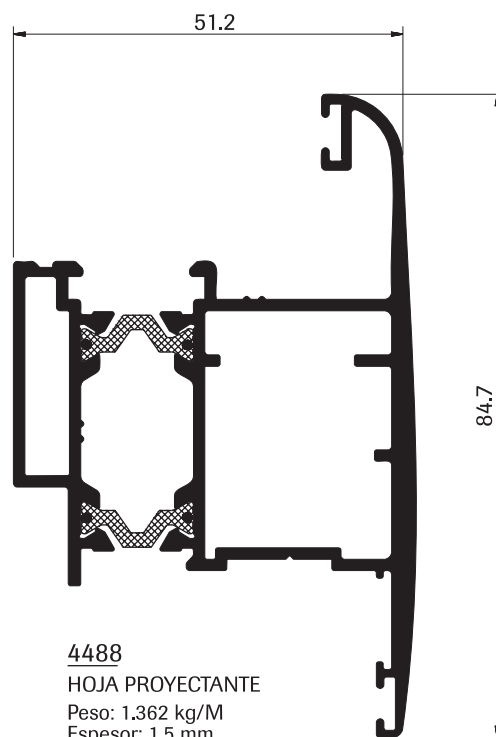

4488
HOJA PROYECTANTE
Peso: 1.362 kg/M
Espesor: 1.5 mm

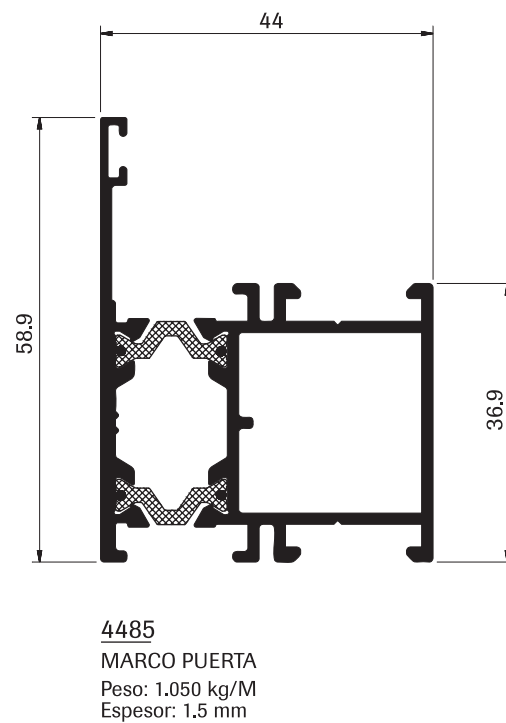
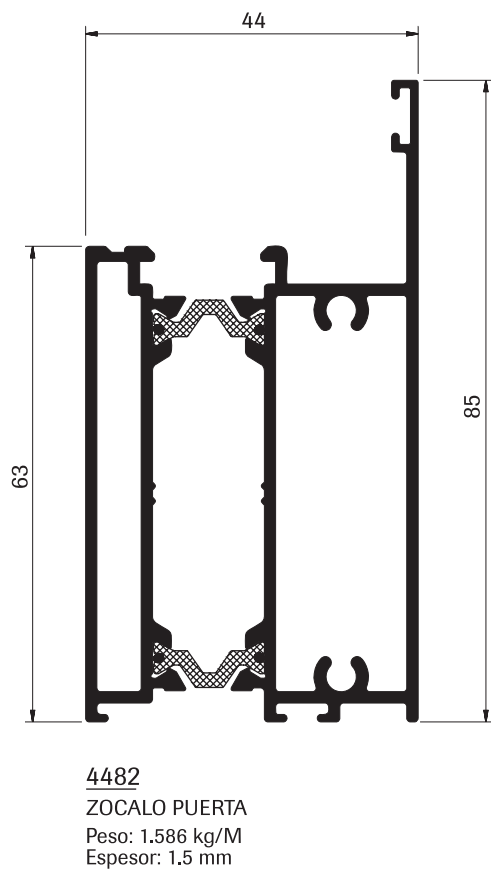
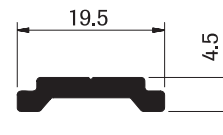
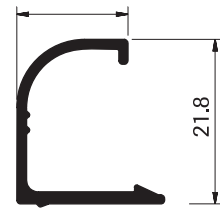
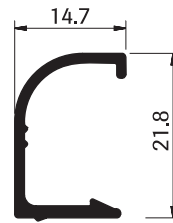
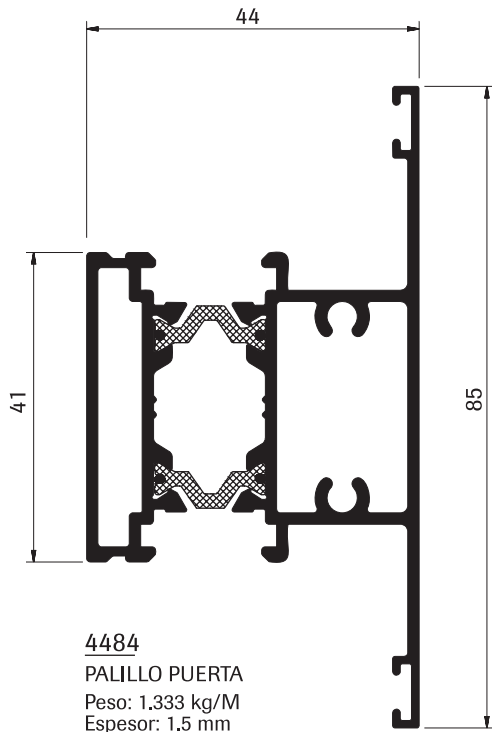

Perfiles

Escala 1:1

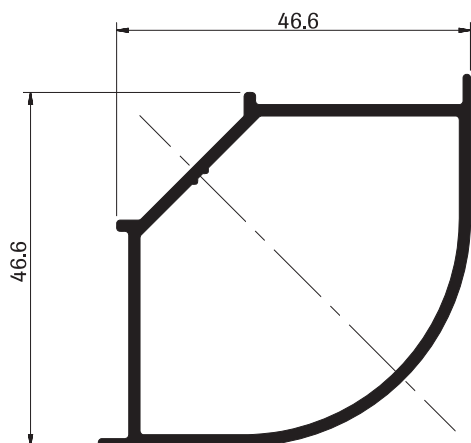

4467
PILAR RODON 90°
 Peso: 0.656 kg/M
 Espesor: 1.5 mm

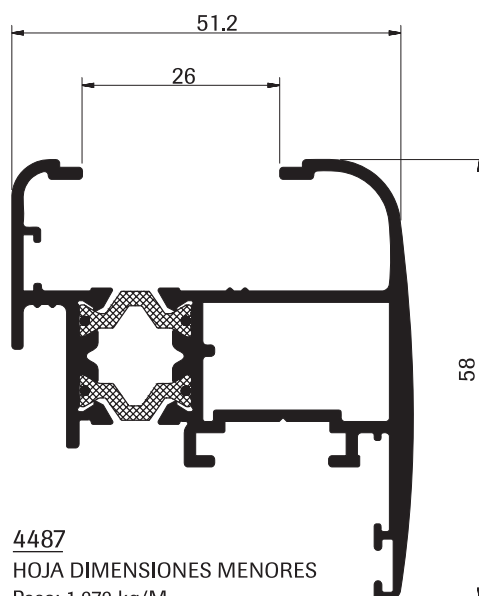

4487
HOJA DIMENSIONES MENORES
 Peso: 1.070 kg/M
 Espesor: 1.5 mm

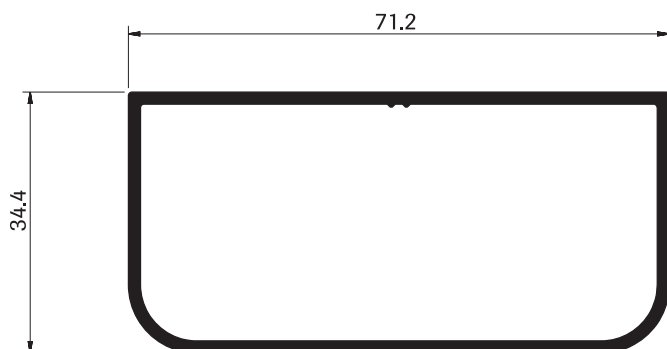

4468
PILAR
 Peso: 0.854 kg/M
 Espesor: 1.6 mm

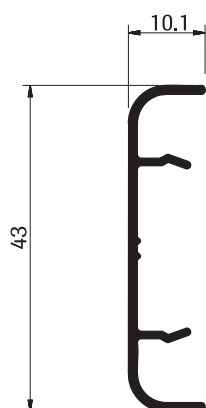

4459
CONTRAMARCO
 Peso: 0.224 kg/M
 Espesor: 1.2 mm

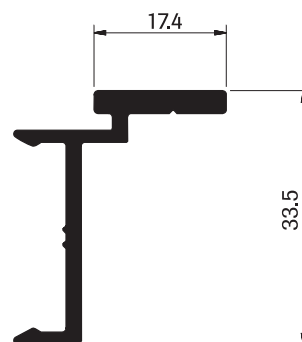

4460
PREMARCO
 Peso: 0.390 kg/M
 Espesor: 2.0 mm

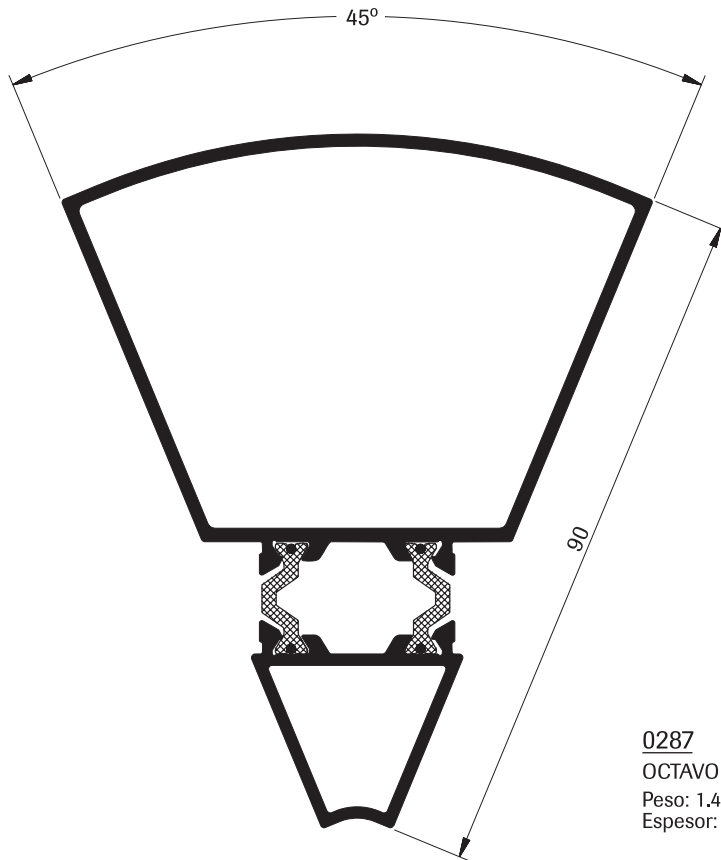

0287
OCTAVO RODON RPT 90 MM.
Peso: 1.432 kg/M
Espesor: 1.5 mm

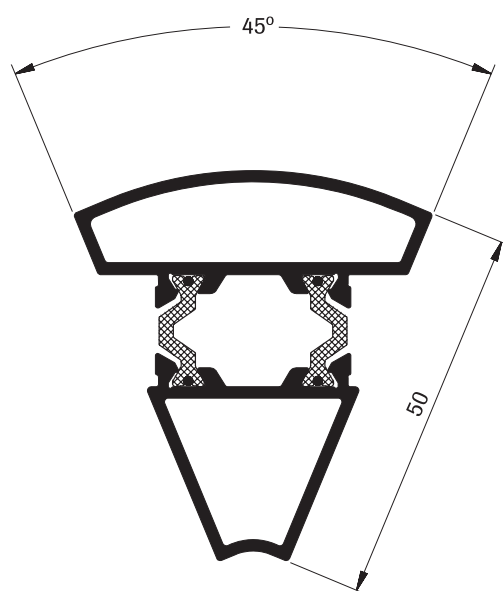

0286
OCTAVO RODON RPT 50 MM.
Peso: 0.912 kg/M
Espesor: 1.5 mm

Superba 44 RPT

Ventana de abatir / proyección / puerta

Ventana proyectante y paño fijo lateral

Escala 1:2

